



3-Pin Microprocessor Power Supply Supervisors



FEATURES

- Precision monitoring of
 - +5.0V (-5%, -10%, -20%),
 - +3.3V (-5%, -10%),
 - +3.0V (-10%) and
 - +2.5V (-5%) power supplies
- Offered in three output configurations:
 - CAT803: Open-Drain Active LOW reset
 - CAT809: Push-Pull Active LOW reset
 - CAT810: Push-Pull Active HIGH reset
- Direct replacements for the MAX803, MAX809 and MAX810 in applications operating over the industrial temperature range
- Reset valid down to $V_{CC} = 1.0V$
- 6 μ A power supply current
- Power supply transient immunity
- Industrial temperature range: -40°C to +85°C
- Available in RoHS-compliant SOT-23 and SC-70 packages

APPLICATIONS

- Computers
- Servers
- Laptops
- Cable modems
- Wireless communications
- Embedded control systems
- White goods
- Power meters
- Intelligent instruments
- PDAs and handheld equipment

PIN CONFIGURATION

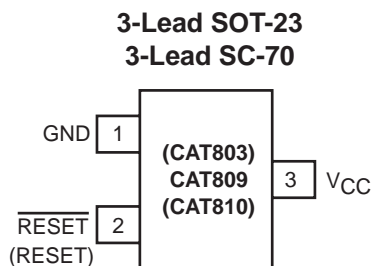

DESCRIPTION

The CAT803, CAT809, and CAT810 are supervisory circuits that monitor power supplies in digital systems. The CAT803, CAT809, and CAT810 are direct replacements for the MAX803, MAX809 and MAX810 in applications operating over the industrial temperature range.

These devices generate a reset signal, which is asserted while the power supply voltage is below a preset threshold level and for at least 140 ms after the power supply level has risen above that level. The underlying floating gate technology, AE²(™) used by Catalyst Semiconductor, makes it possible to offer any custom reset threshold value. Seven industry standard threshold levels are offered to support +5.0V, +3.3V, +3.0V and +2.5V systems.

The CAT803 has an open-drain $\overline{\text{RESET}}$ output (active LOW). The CAT803 requires a pull-up resistor on the reset output.

The CAT809 features a push-pull $\overline{\text{RESET}}$ output (active LOW) and the CAT810 features a push-pull RESET output (active HIGH).

Fast transients on the power supply are ignored and the output is guaranteed to be in the correct state at V_{CC} levels as low as 1.0V.

The CAT803, CAT809, and CAT810 are available in both the compact 3-pin SOT-23 and SC-70 packages.

For Ordering Information details, see page 11.

THRESHOLD SUFFIX SELECTOR

Nominal Threshold Voltage	Threshold Suffix Designation
4.63V	L
4.38V	M
4.00V	J
3.08V	T
2.93V	S
2.63V	R
2.32V	Z

PIN DESCRIPTIONS

Pin Number			Name	Description
CAT803	CAT809	CAT810		
1	1	1	GND	Ground
2	2	—	RESET \bar	Active LOW reset. RESET is asserted if V_{CC} falls below the reset threshold and remains low for at least 140ms after V_{CC} rises above the reset threshold.
—	—	2	RESET	Active HIGH reset. RESET is asserted if V_{CC} falls below the reset threshold and remains high for at least 140ms after V_{CC} rises above the reset threshold.
3	3	3	V_{CC}	Power supply voltage that is monitored.

BLOCK DIAGRAMS

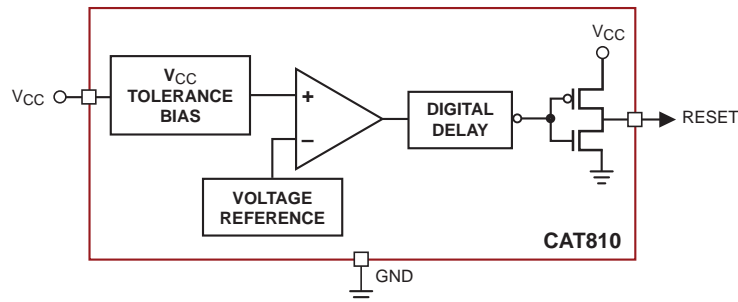
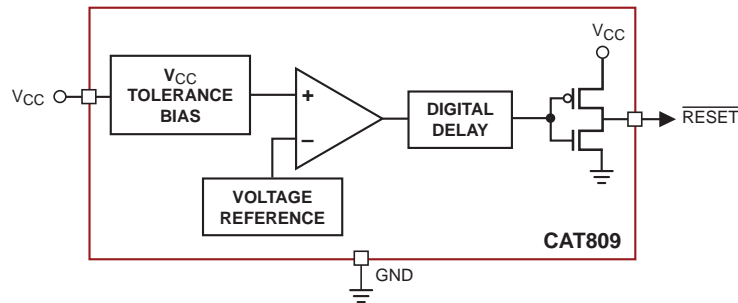
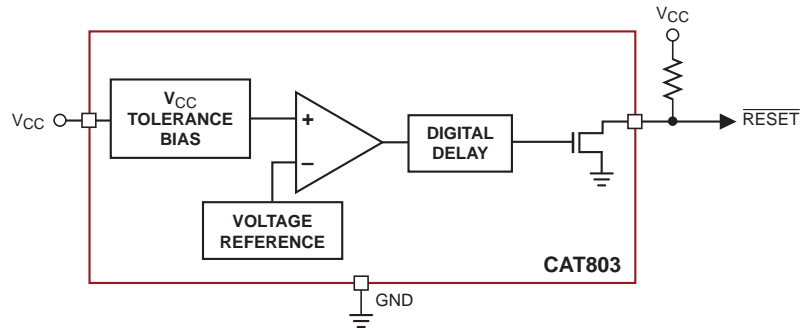

ABSOLUTE MAXIMUM RATINGS⁽¹⁾

Any pin with respect to ground	-0.3V to +6.0V
Input Current, V_{CC}	20mA
Output Current, RESET, $\overline{\text{RESET}}$	20mA
Rate of Rise, V_{CC}	100V/ μ s
Continuous Power Dissipation	
Derate 2.2mW/ $^{\circ}$ C above 70 $^{\circ}$ C (SC70)	175 mW
Derate 4mW/ $^{\circ}$ C above 70 $^{\circ}$ C (SOT23)	320 mW
Operating Temperature Range	-40 $^{\circ}$ C to +85 $^{\circ}$ C
Storage Temperature Range	-65 $^{\circ}$ C to +105 $^{\circ}$ C
Lead Soldering Temperature (10 sec)	300 $^{\circ}$ C

Note:

(1) Stresses above those listed under "Absolute Maximum Ratings" may cause permanent damage to the device. These are stress ratings only, and functional operation of the device at these or any other conditions outside of those listed in the operational sections of this specification is not implied. Exposure to any absolute maximum rating for extended periods may affect device performance and reliability.

ELECTRICAL CHARACTERISTICS

V_{CC} = Full range, T_A = -40 $^{\circ}$ C to +85 $^{\circ}$ C unless otherwise noted. Typical values at T_A = +25 $^{\circ}$ C and V_{CC} = 5V for the L/M/J versions, V_{CC} = 3.3V for the T/S versions, V_{CC} = 3V for the R version and V_{CC} = 2.5V for the Z version.

Parameter	Symbol	Conditions	Min	Typ	Max	Units	
V_{CC} Range		T_A = 0 $^{\circ}$ C to +70 $^{\circ}$ C	1.0		5.5	V	
		T_A = -40 $^{\circ}$ C to +85 $^{\circ}$ C	1.2		5.5		
Supply Current	I_{CC}	T_A = -40 $^{\circ}$ C to +85 $^{\circ}$ C	V_{CC} < 5.5V, J/L/M		8	20	μ A
			V_{CC} < 3.6V, R/S/T/Z		6	15	
Reset Threshold Voltage	V_{TH}	L Threshold	T_A = +25 $^{\circ}$ C	4.56	4.63	4.70	V
			T_A = -40 $^{\circ}$ C to +85 $^{\circ}$ C	4.50		4.75	
		M Threshold	T_A = +25 $^{\circ}$ C	4.31	4.38	4.45	
			T_A = -40 $^{\circ}$ C to +85 $^{\circ}$ C	4.25		4.50	
		J Threshold	T_A = +25 $^{\circ}$ C	3.93	4.00	4.06	
			T_A = -40 $^{\circ}$ C to +85 $^{\circ}$ C	3.89		4.10	
		T Threshold	T_A = +25 $^{\circ}$ C	3.04	3.08	3.11	
			T_A = -40 $^{\circ}$ C to +85 $^{\circ}$ C	3.00		3.15	
		S Threshold	T_A = +25 $^{\circ}$ C	2.89	2.93	2.96	
			T_A = -40 $^{\circ}$ C to +85 $^{\circ}$ C	2.85		3.00	
		R Threshold	T_A = +25 $^{\circ}$ C	2.59	2.63	2.66	
			T_A = -40 $^{\circ}$ C to +85 $^{\circ}$ C	2.55		2.70	
		Z Threshold	T_A = +25 $^{\circ}$ C	2.28	2.32	2.35	
			T_A = -40 $^{\circ}$ C to +85 $^{\circ}$ C	2.25		2.38	

CAT803, CAT809, CAT810

ELECTRICAL CHARACTERISTICS (continued)

V_{CC} = Full range, T_A = -40°C to +85°C unless otherwise noted. Typical values at T_A = +25°C and V_{CC} = 5V for L/M/J versions, V_{CC} = 3.3V for T/S versions, V_{CC} = 3V for R version and V_{CC} = 2.5V for Z version.

Parameter	Symbol	Conditions	Min	Typ ⁽¹⁾	Max	Units
Reset Threshold Tempco				30		ppm/°C
V_{CC} to Reset Delay (Note 2)	T_D	$V_{CC} = V_{TH}$ to ($V_{TH} - 100$ mV)		20		μs
Reset Active Timeout Period	T_R	$T_A = -40^\circ\text{C}$ to $+85^\circ\text{C}$	140	240	460	ms
$\overline{\text{RESET}}$ Output Voltage Low (Open-drain active LOW, CAT803 and push-pull, active LOW, CAT809)	V_{OL}	$V_{CC} = V_{TH}$ min, $I_{SINK} = 1.2\text{mA}$ CAT803R/S/T/Z, CAT809R/S/T/Z			0.3	V
		$V_{CC} = V_{TH}$ min, $I_{SINK} = 3.2\text{mA}$ CAT803J/L/M, CAT809J/L/M			0.4	
		$V_{CC} > 1.0\text{V}$, $I_{SINK} = 50\mu\text{A}$			0.3	
$\overline{\text{RESET}}$ Output Voltage High (Push-pull, active LOW, CAT809)	V_{OH}	$V_{CC} = V_{TH}$ max, $I_{SOURCE} = 500\mu\text{A}$ CAT809R/S/T/Z	$0.8 V_{CC}$			V
		$V_{CC} = V_{TH}$ max, $I_{SOURCE} = 800\mu\text{A}$ CAT809J/L/M	$V_{CC} - 1.5$			
RESET Output Voltage Low (Push-pull, active HIGH, CAT810)	V_{OL}	$V_{CC} > V_{TH}$ max, $I_{SINK} = 1.2\text{mA}$ CAT810R/S/T/Z			0.3	V
		$V_{CC} > V_{TH}$ max, $I_{SINK} = 3.2\text{mA}$ CAT810J/L/M			0.4	
RESET Output Voltage High (Push-pull active HIGH, CAT810)	V_{OH}	$1.8\text{V} < V_{CC} < V_{TH}$ min, $I_{SOURCE} = 150\mu\text{A}$	$0.8 V_{CC}$			V

Notes:

- (1) Production testing done at $T_A = +25^\circ\text{C}$; limits over temperature guaranteed by design only.
- (2) $\overline{\text{RESET}}$ output for the CAT809; RESET output for the CAT810.

TYPICAL OPERATING CHARACTERISTICS

V_{CC} = Full range, T_A = -40°C to +85°C unless otherwise noted. Typical values at T_A = +25°C and V_{CC} = 5V for L/M/J versions, V_{CC} =3.3V for T/S versions, V_{CC} = 3V for R version and V_{CC} = 2.5V for Z version.

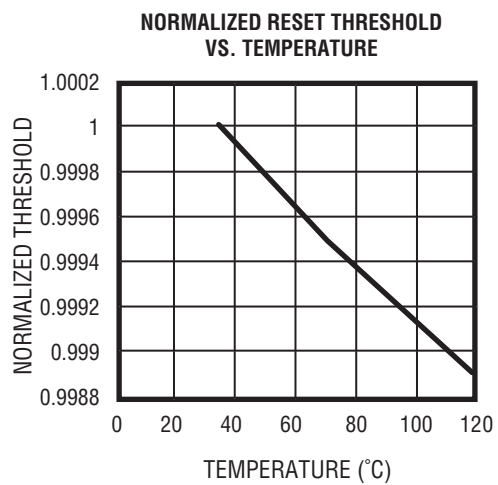
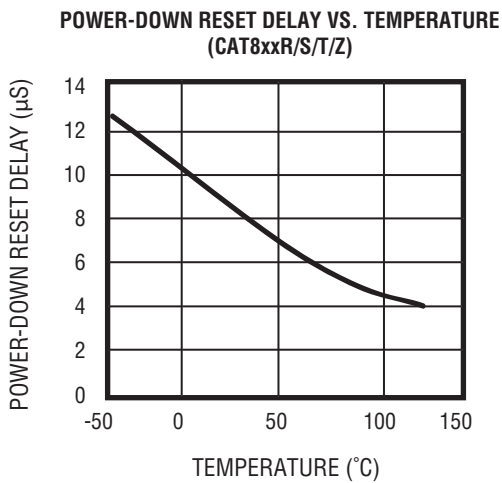
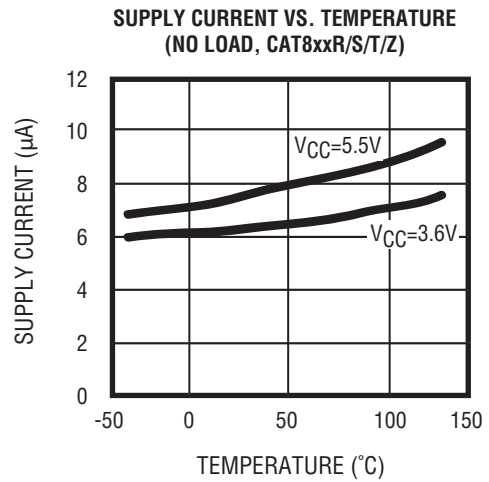
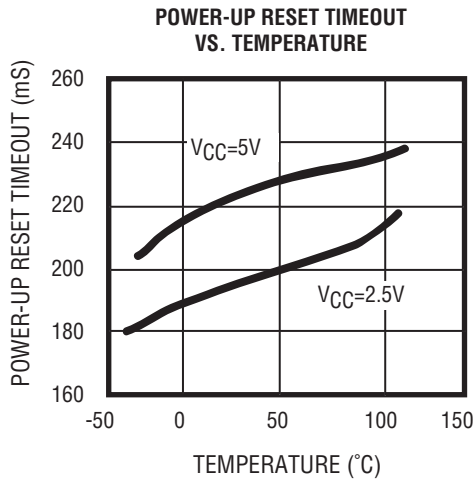

DETAILED DESCRIPTIONS

RESET TIMING

The reset signal is asserted LOW for the CAT803/CAT809 and HIGH for the CAT810 when the power supply voltage falls below the threshold trip voltage and remains asserted for at least 140ms after the power supply voltage has risen above the threshold.

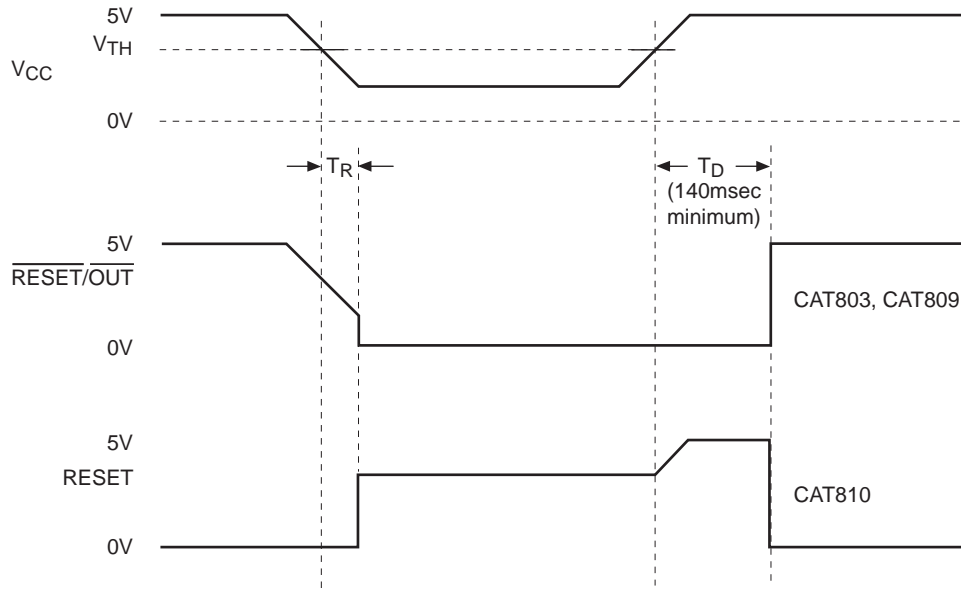

Figure 1. Reset Timing Diagram

V_{CC} TRANSIENT RESPONSE

The CAT803/CAT809/CAT810 protect μPs against brownout failure. Short duration transients of $4\mu\text{sec}$ or less and 100mV amplitude typically do not cause a false RESET.

Figure 2 shows the maximum pulse duration of negative-going V_{CC} transients that do not cause a reset condition.

As the amplitude of the transient goes further below the threshold (increasing $V_{TH} - V_{CC}$), the maximum pulse duration decreases. In this test, the V_{CC} starts from an initial voltage of 0.5V above the threshold and drops below it by the amplitude of the overdrive voltage ($V_{TH} - V_{CC}$).

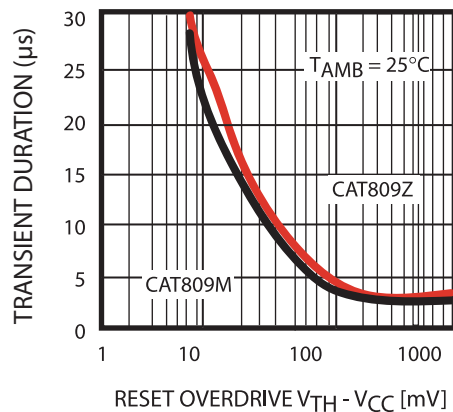

Figure 2. Maximum Transient Duration Without Causing a Reset Pulse vs. Reset Comparator Overdrive

VALID RESET WITH V_{CC} UNDER 1.0V

To ensure that the CAT809 $\overline{\text{RESET}}$ pin is in a known state when V_{CC} is under 1.0V, a $>10\text{k}\Omega$ pull-down resistor between $\overline{\text{RESET}}$ pin and GND is recommended. For the CAT810, a pull-up resistor from RESET pin to V_{CC} is needed.

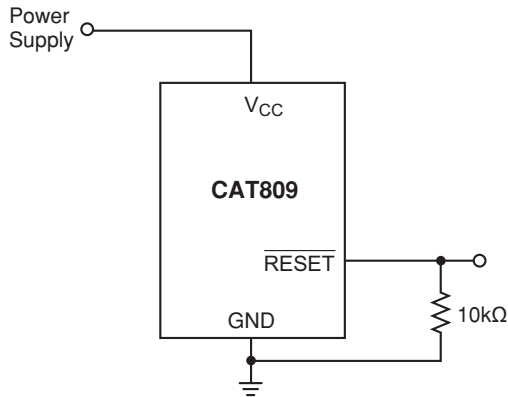

Figure 3. $\overline{\text{RESET}}$ Valid with V_{CC} Under 1.0V

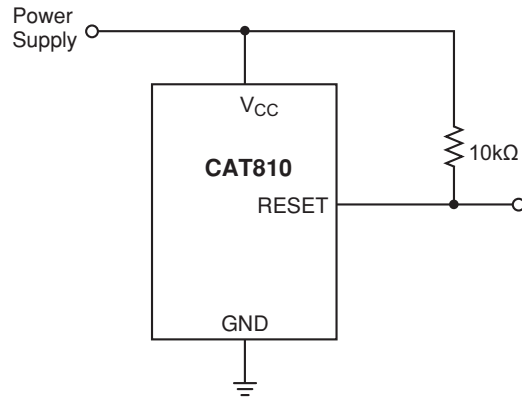

Figure 4. RESET Valid with V_{CC} Under 1.1V

BI-DIRECTIONAL RESET PIN INTERFACING

The CAT809/810 can interface with $\mu\text{P}/\mu\text{C}$ bi-directional reset pins by connecting a $4.7\text{k}\Omega$ resistor in series with the CAT809/810 reset output and the $\mu\text{P}/\mu\text{C}$ bi-directional reset pin.

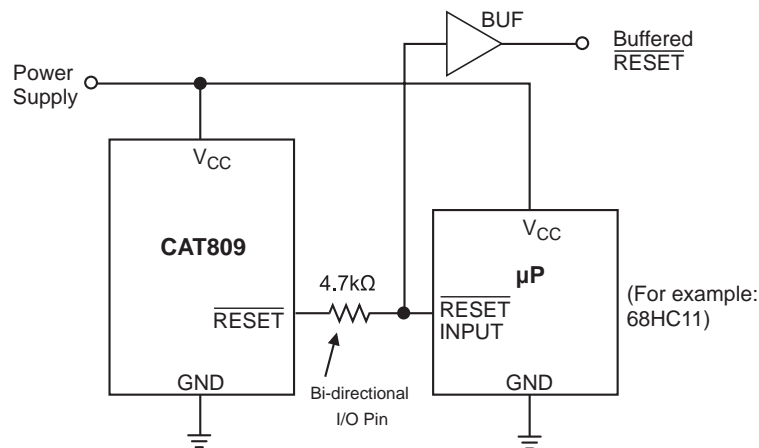

Figure 5. Bi-directional Reset Pin Interfacing

CAT803 OPEN-DRAIN $\overline{\text{RESET}}$ APPLICATION

The CAT803 features an open-drain $\overline{\text{RESET}}$ output and therefore needs a pull-up resistor on the output for proper operation, as shown on Figure 6. An advantage of the open-drain output includes the ability to “wire AND” several outputs together to form an inexpensive logic circuit. It is also possible to have the pull-up resistor connected to a different supply which can be higher than the CAT803 V_{CC} pin. The value of the pull-up resistor is not critical in most applications, typical values being between 5k Ω and 10k Ω .

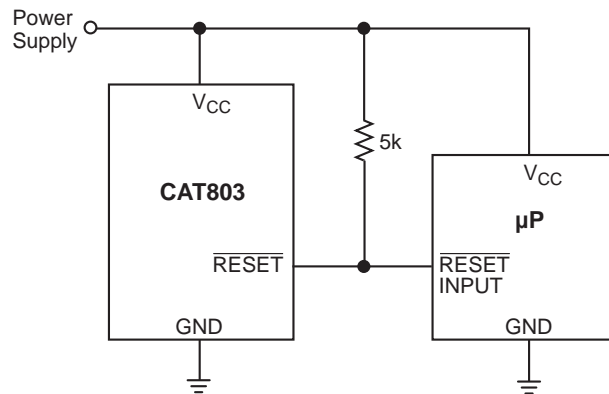
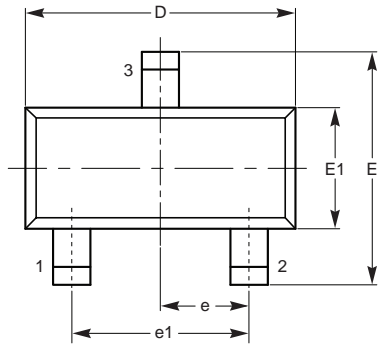

Figure 6. Typical CAT803 Open-Drain Circuit Configuration

PACKAGE OUTLINE DRAWINGS

SOT-23 3-Lead (TB)



TOP VIEW

SYMBOL	MIN	NOM	MAX
A	0.89		1.12
A1	0.013		0.10
b	0.37		0.50
c	0.085		0.18
D	2.80		3.04
E	2.10		2.64
E1	1.20		1.40
e	0.95 BSC		
e1	1.90 BSC		
L	0.400 REF		
L1	0.540 REF		
θ	0°		8°

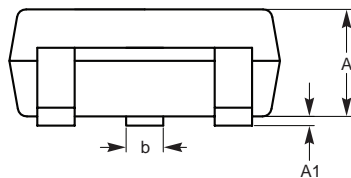

SIDE VIEW

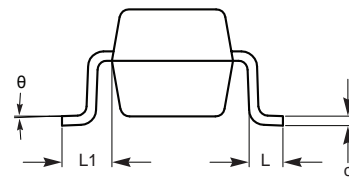

END VIEW

For current Tape and Reel information, download the PDF file from:
www.catsemi.com/documents/tapeandreel.pdf

Notes:

- (1) All dimensions are in millimeters. Angles in degrees.
- (2) Complies with JEDEC standard TO-236.

SC-70 3-Lead (SD)

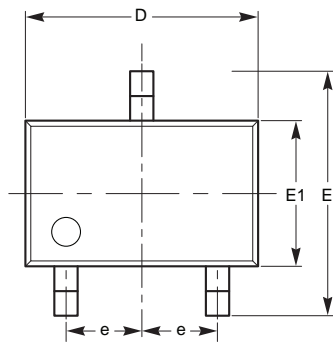

TOP VIEW

SYMBOL	MIN	NOM	MAX
A	0.80		1.10
A1	0.00		0.10
A2	0.80	0.90	1.00
b	0.15		0.30
c	0.08		0.22
D	1.80	2.00	2.20
E	1.80	2.10	2.40
E1	1.15	1.25	1.35
e	0.65 BSC		
L	0.26	0.36	0.46
L1	0.42 REF		
L2	0.15 BSC		
θ	0°		8°
θ_1	4°		10°

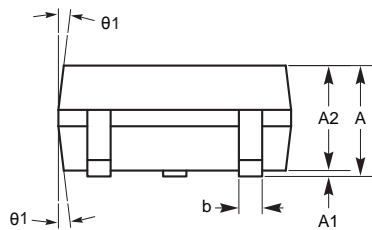

SIDE VIEW

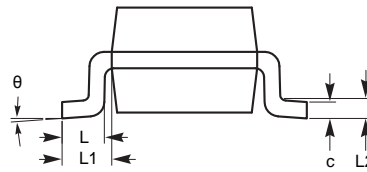

END VIEW

For current Tape and Reel information, download the PDF file from:
www.catsemi.com/documents/tapeandreeel.pdf

Notes:

- (1) All dimensions are in millimeters. Angles in degrees.
- (2) Complies with JEDEC standard MO-203.

EXAMPLE OF ORDERING INFORMATION ⁽²⁾ ⁽³⁾ ⁽⁴⁾

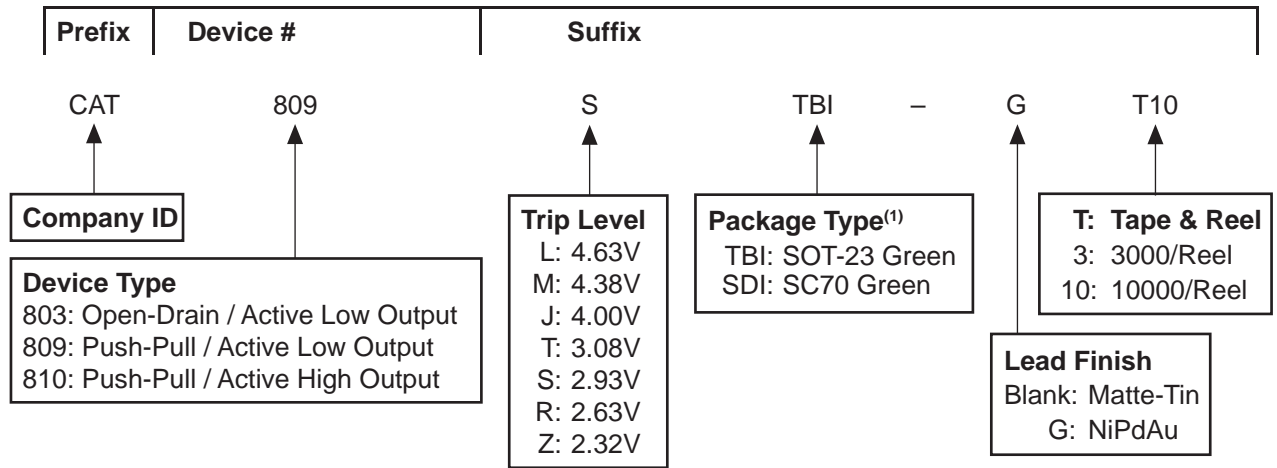

Notes:

- (1) All packages are RoHS-compliant (Lead-free, Halogen-free).
- (2) The standard lead finish is NiPdAu. Contact factory for other lead finishes.
- (3) The device used in the example above is a CAT809STBI-GT10 (Push-Pull / Active Low Output, trip level of 2.85V to 3.00V NiPdAu, Tape and Reel).
- (4) For additional package and temperature options, please contact your nearest ON Semiconductor Sales office.

TOP MARKING

Device ⁽¹⁾	SOT-23 PbSn Finish ⁽²⁾	SOT-23 RoHS Matte Finish ⁽²⁾	SOT-23 RoHS NiPdAu Finish ⁽²⁾⁽³⁾	SC70 PbSn Finish ⁽²⁾	SC70 RoHS Matte Finish ⁽²⁾	SC70 RoHS NiPdAu Finish ⁽²⁾⁽³⁾
CAT803x	N/A	RPYM	RNYM	N/A	RP__	RN__
CAT809x	PAYM	PBYM	NRYM	PA__	PB__	NR__
CAT810x	PCYM	PDYM	NSYM	PC__	PD__	NS__

Notes:

- (1) All theshold trip level options have the same marking.
- (2) The "YM" in the SOT-23 package marking indicates the Year and Month of roduction and the "_" in the SC70 package marking indicates the assembly location.
- (3) All NiPdAu devices will be marked to indicate product type and package. Threshold and full part numbers will be provided on box and reel labels as well as all Shipping documents.

CAT803, CAT809, CAT810

ORDERING PART NUMBER

CAT803LSDI ⁽¹⁾	CAT803LSDI-G	CAT809LSDI ⁽¹⁾	CAT809LSDI-G	CAT810LSDI ⁽¹⁾	CAT810LSDI-G
CAT803MSDI ⁽¹⁾	CAT803MSDI-G	CAT809MSDI ⁽¹⁾	CAT809MSDI-G	CAT810MSDI ⁽¹⁾	CAT810MSDI-G
CAT803JSDI ⁽¹⁾	CAT803JSDI-G	CAT809JSDI ⁽¹⁾	CAT809JSDI-G	CAT810JSDI ⁽¹⁾	CAT810JSDI-G
CAT803TSDI ⁽¹⁾	CAT803TSDI-G	CAT809TSDI ⁽¹⁾	CAT809TSDI-G	CAT810TSDI ⁽¹⁾	CAT810TSDI-G
CAT803SSDI ⁽¹⁾	CAT803SSDI-G	CAT809SSDI ⁽¹⁾	CAT809SSDI-G	CAT810SSDI ⁽¹⁾	CAT810SSDI-G
CAT803RSDI ⁽¹⁾	CAT803RSDI-G	CAT809RSDI ⁽¹⁾	CAT809RSDI-G	CAT810RSDI ⁽¹⁾	CAT810RSDI-G
CAT803ZSDI ⁽¹⁾	CAT803ZSDI-G	CAT809ZSDI ⁽¹⁾	CAT809ZSDI-G	CAT810ZSDI ⁽¹⁾	CAT810ZSDI-G
CAT803LTBI ⁽¹⁾	CAT803LTBI-G	CAT809LTBI ⁽¹⁾	CAT809LTBI-G	CAT810LTBI ⁽¹⁾	CAT810LTBI-G
CAT803MTBI ⁽¹⁾	CAT803MTBI-G	CAT809MTBI ⁽¹⁾	CAT809MTBI-G	CAT810MTBI ⁽¹⁾	CAT810MTBI-G
CAT803JTBI ⁽¹⁾	CAT803JTBI-G	CAT809JTBI ⁽¹⁾	CAT809JTBI-G	CAT810JTBI ⁽¹⁾	CAT810JTBI-G
CAT803TTBI ⁽¹⁾	CAT803TTBI-G	CAT809TTBI ⁽¹⁾	CAT809TTBI-G	CAT810TTBI ⁽¹⁾	CAT810TTBI-G
CAT803STBI ⁽¹⁾	CAT803STBI-G	CAT809STBI ⁽¹⁾	CAT809STBI-G	CAT810STBI ⁽¹⁾	CAT810STBI-G
CAT803RTBI ⁽¹⁾	CAT803RTBI-G	CAT809RTBI ⁽¹⁾	CAT809RTBI-G	CAT810RTBI ⁽¹⁾	CAT810RTBI-G
CAT803ZTBI ⁽¹⁾	CAT803ZTBI-G	CAT809ZTBI ⁽¹⁾	CAT809ZTBI-G	CAT810ZTBI ⁽¹⁾	CAT810ZTBI-G

Note:

(1) Contact Factory for availability.

REVISION HISTORY

Date	Rev.	Description
29-Oct-03	N	Updated VCC Transient Response text and Figure 2
30-Oct-03	O	Updated Power Up Reset Timeout vs. Temperature curve
3-Oct-04	P	Corrected temperature range Updated Description Updated Ordering Information Updated Absolute Maximum Ratings Updated Electrical Characteristics
23-Mar-04	Q	Updated Description Updated Ordering Information Updated Absolute Maximum Ratings Updated Electrical Characteristics Updated Typical Operating Characteristics Updated Package Information
25-Mar-04	R	Changed Preliminary designation to Final Updated Max Reset Active Timeout Period in Electrical Characteristics Updated package drawings
5-Oct-04	S	Updated top marking table
28-Feb-05	T	Updated Features Updated Ordering Information Updated Top Marking
17-Feb-06	Q	Updated Typical Operating Characteristics
10-Aug-06	U	Updated Features Updated Description Updated Max Reset Active Timeout Period in Electrical Characteristics Updated Figure 1 Updated Package Information Correct Revision Number
17-Oct-06	V	Updated Top Marking Updated Detailed Description Adding CAT803
12-Feb-07	W	Updated Electrical Characteristics Updated Figure 1 Updated Ordering Information
20-Mar-07	X	Updated Detailed Descriptions
31-Jan-08	Y	Added MD- to Document Number Added Block Diagrams Updated Package Outline Drawings Updated Example of Ordering Information Updated Ordering Part Number
05-Nov-08	Z	Change logo and fine print to ON Semiconductor

ON Semiconductor and  are registered trademarks of Semiconductor Components Industries, LLC (SCILLC). SCILLC reserves the right to make changes without further notice to any products herein. SCILLC makes no warranty, representation or guarantee regarding the suitability of its products for any particular purpose, nor does SCILLC assume any liability arising out of the application or use of any product or circuit, and specifically disclaims any and all liability, including without limitation special, consequential or incidental damages. "Typical" parameters which may be provided in SCILLC data sheets and/or specifications can and do vary in different applications and actual performance may vary over time. All operating parameters, including "Typicals" must be validated for each customer application by customer's technical experts. SCILLC does not convey any license under its patent rights nor the rights of others. SCILLC products are not designed, intended, or authorized for use as components in systems intended for surgical implant into the body, or other applications intended to support or sustain life, or for any other application in which the failure of the SCILLC product could create a situation where personal injury or death may occur. Should Buyer purchase or use SCILLC products for any such unintended or unauthorized application, Buyer shall indemnify and hold SCILLC and its officers, employees, subsidiaries, affiliates, and distributors harmless against all claims, costs, damages, and expenses, and reasonable attorney fees arising out of, directly or indirectly, any claim of personal injury or death associated with such unintended or unauthorized use, even if such claim alleges that SCILLC was negligent regarding the design or manufacture of the part. SCILLC is an Equal Opportunity/Affirmative Action Employer. This literature is subject to all applicable copyright laws and is not for resale in any manner.

PUBLICATION ORDERING INFORMATION

LITERATURE FULFILLMENT:

Literature Distribution Center for ON Semiconductor

P.O. Box 5163, Denver, Colorado 80217 USA

Phone: 303-675-2175 or 800-344-3860 Toll Free USA/Canada

Fax: 303-675-2176 or 800-344-3867 Toll Free USA/Canada

Email: orderlit@onsemi.com

N. American Technical Support: 800-282-9855 Toll Free
USA/Canada

Europe, Middle East and Africa Technical Support:
Phone: 421 33 790 2910

Japan Customer Focus Center:
Phone: 81-3-5773-3850

ON Semiconductor Website: www.onsemi.com

Order Literature: <http://www.onsemi.com/orderlit>

For additional information, please contact your local
Sales Representative
